

BALL VALVES INTEC

K230, DN80 - DN250, PN16/40

trunnion mounted ball, soft seated

single side spring loaded seat ring, free outlet

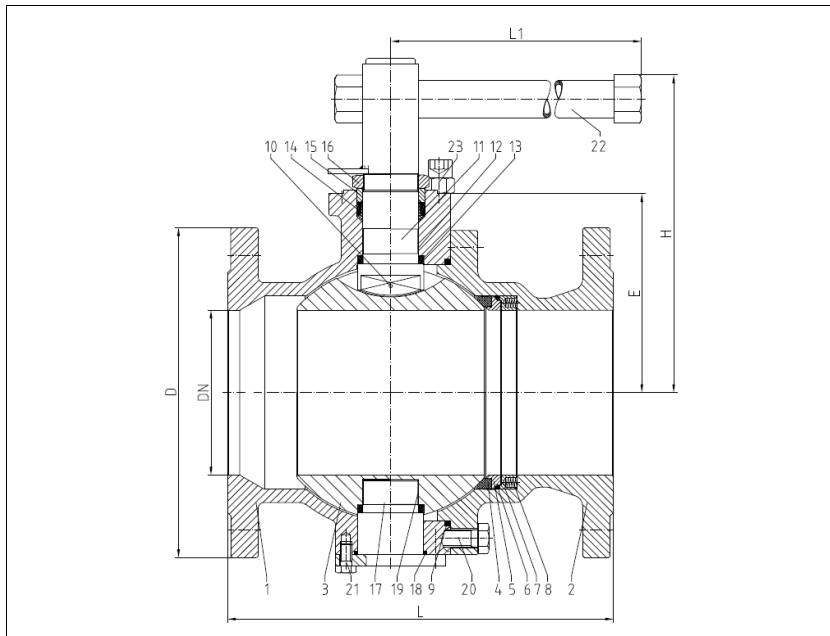

Flanged ball valve

full bore

face to face acc. to EN 558, GR.1

face to face acc. to EN 558, GR.27

flanges acc. to EN 1092

Specification:

Two-piece ball valve with flanges acc. to EN 1092, face to face dimensions acc. to EN 558, GR.1/GR.27, full bore, free outlet, blow-out-proof stem, body material stainless steel (1.4408) or carbon steel (1.0619), antistatic device, free of non ferrous metals, trunnion mounted ball, seat full chambered, stem packing Graphite/KFGN/KFAM cone ring system dynamic loaded adjustable, top flange DIN EN ISO 5211, approved by PED, certified acc. to GERMAN clean air act VDI 2440, Fire-Safe acc. to API 607 and DIN EN ISO 10497, with lever.

Marking: INTEC K230

No.	Part	Material	Material
Standard design			
1	body	1.0619	1.4408
2	cap	1.0619	1.4408
3	ball	1.4408	
4	seat	KFGN/KFM	
5	seat bearing ring	1.4571/1.4404	
6	seat seal	KF	
7	follower ring	1.4571/1.4404	
8	spiral spring	1.4401	
9	body seal	KF	
10	antistatic element	1.4401/1.4571/1.4404	
11	stem	1.4462	
12	below stem bearing	1.4401/KF	
13	below seal	KFGN/Graphite	
14	upper seal	KFAM/Graphite	
15	upper stem bearing	1.4401/KF	
16	hex. nut self-locking	A2/1.4301	
17	bearing neck	1.4571/1.4404	
18	trunnion seal	KF	
19	bearing	1.4401/KF	
20+21	hex. screw	A4-70	
22	lever	1.4408/1.4308/steel zincplated	
23	stopper	A2	
Fire-Safe design			
6	seat seal	Graphite	
8	spiral spring	Inconel X750	
9	combined body seal	KF-Graphite	
11	Fire-Safe seal ring	Graphite	
	ring	1.4571/1.4404	
18	thrust washer	PEEK	
	trunnion seal	KF-Graphite	

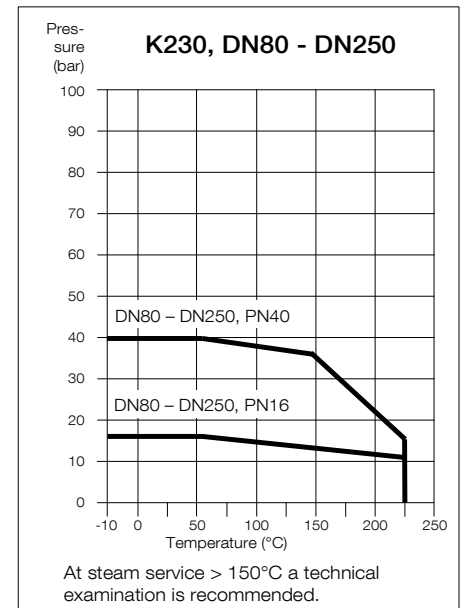

Ordering example:
INTEC K230, DN200, PN40,
GR. 27, 1.4408, Fire-Safe

Other flange connections and materials on request.

Dimensions

DN mm	PN	dimensions (mm)			L GR. 1	L GR. 27	D	E	H1	top flange ISO	torque Nm*	ca. weight kg	
		H	L1	L GR. 1								GR. 1	GR. 27
80	40	194	500	310	180	200	112,5	155	F10	160	26	24	
100	16	221.5	500	350	190	220	137	179.5	F12	130	33	32	
100	40	221.5	500	350	190	235	137	179.5	F12	245	34	33	
125	16	246.5	700	-	325	250	164	206.5	F12	175	-	57	
125	40	246.5	700	-	325	270	164	206.5	F12	360	-	59	
150	16	263	700	-	350	285	181	229.5	F12	255	-	81	
150	40	263	700	-	350	300	181	229.5	F12	555**	-	85	
200	16	304	1000	-	400	340	225	284.5	F14	480	-	153	
200	40	304	1000	-	400	375	225	284.5	F14	1100**	-	161	
250	16	340.5	1200	-	450	405	261.5	321	F14/F16	750**	-	258	
250	40	340.5	1200	-	450	450	261.5	321	F14/F16	1725**	-	274	

* Necessary torque measured with treated water at Δ P acc. to pressure class and room temperature

** gearbox recommended